

# OAM1141-T40-2

## Acousto-Optic Modulator

Off-Axis



0710

The OAM1141 series are specifically designed for operation as compact acousto-optic frequency-shifters at 633nm. Note: These devices have a preferred orientation.

### FEATURES

**Small Size**  
**Low Drive Power**  
**Good Temperature Stability**

### DRIVERS

**Model 521c-L (Digital)**  
**Model 531c-L (Analog)**

### SPECIFICATIONS

Operating Wavelength:	633nm
Interaction Material:	TeO <sub>2</sub> (Off-Axis Mode)
Acoustic Velocity:	664 m/s (Nominal)
Active Aperture:	2mm
Centre Frequency (f <sub>c</sub> )	40MHz
RF Bandwidth (Δf)	10MHz
Input Impedance:	50Ω (Nominal)
VSWR:	< 1.5 :1 at f <sub>c</sub>
Laser Polarization:	Linear, Horizontal
Optical Power:	< 5W

### PERFORMANCE

Wavelength:	633 nm
RF Drive Power:	< 0.5 W
Input Angle (Deg @ 40MHz)	5.5° (Nominal)
Beam Separation (Deg @ 40 MHz):	2.2°
Diffraction Efficiency	≥85% min > 90% typ
Static Insertion loss	<3% max, < 2% typ

#### ALL SPECIFICATIONS SUBJECT TO CHANGE WITHOUT NOTICE

ISOMET CORP, 5263 Port Royal Rd, Springfield, VA 22151, USA.

Tel: (703) 321 8301 Fax: (703) 321 8546

E-mail: [ISOMET@ISOMET.COM](mailto:ISOMET@ISOMET.COM) Web Page: [WWW.ISOMET.COM](http://WWW.ISOMET.COM)

#### Quality Assured.

**In-house: Crystal Growth,  
 Optical Polishing,  
 A/R coating, Vacuum Bonding**



# OAM1141-T40-2

## Acousto-Optic Modulator

Off-Axis



0710

### OUTLINE DRAWING

Dimensions: mm

Case material: Aluminium

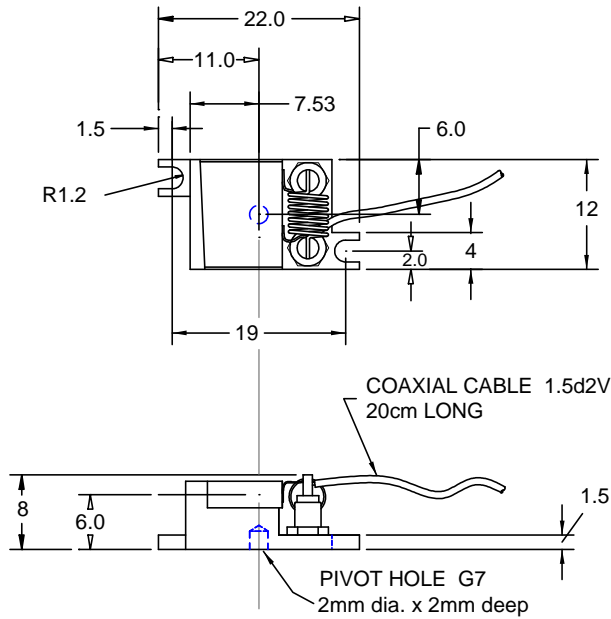

### ORIENTATION

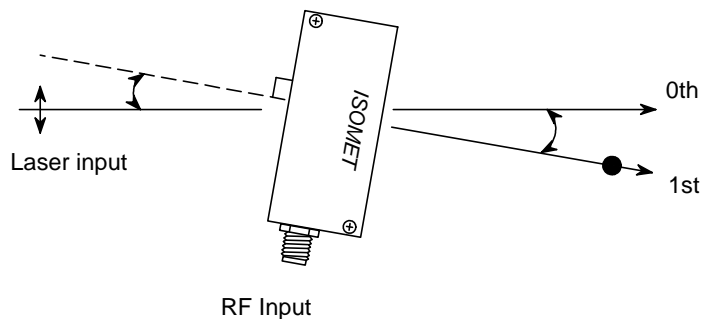

**ALL SPECIFICATIONS SUBJECT TO CHANGE WITHOUT NOTICE**

ISOMET CORP, 5263 Port Royal Rd, Springfield, VA 22151, USA.

Tel: (703) 321 8301 Fax: (703) 321 8546

E-mail: [ISOMET@ISOMET.COM](mailto:ISOMET@ISOMET.COM) Web Page: [WWW.ISOMET.COM](http://WWW.ISOMET.COM)

**Quality Assured.**

**In-house: Crystal Growth,  
Optical Polishing,  
A/R coating, Vacuum Bonding**