

1202-4

Acousto-Optic Modulator



1106

AO Modulator designed for High Power NIR Fibre and DPSS laser applications

SPECIFICATIONS

Spectral Range:	NIR
Operating Wavelength:	1.064 μ m / 1.1 μ m (others on request)
Interaction Medium:	Dense Flint Glass
Acoustic Velocity:	3.6mm/ μ s
Centre Frequency (fc):	40MHz
RF Bandwidth (Δ f):	20MHz
Input Impedance:	50 Ω
Input VSWR:	< 1.5:1 at 40MHz
Clear Aperture:	9 mmH x 14 mmL
Active Aperture:	4 mmH x 14 mmL
Optical Insertion Loss:	< 3%
Reflectivity:	< 0.5%/Surface
Laser Polarization:	Random
Water Cooling (minimum):	1litre/minute at < 20°C
Outline Dimensions:	(See reverse)

TYPICAL PERFORMANCE at 1.064 μ m

Optical Power:	100 Watts **	
Input beam diameter :	2mm	4mm
Optical access time :	0.35us	0.70us
Diffraction Efficiency:	> 85% *	> 85% *
RF Power:	20 Watts nominal	
Bragg Angle:	5.9 mrad	
Separation Angle at fc :	11.7 mrad	

* Single mode input

** For higher powers please contact Isomet

ALL SPECIFICATIONS SUBJECT TO CHANGE WITHOUT NOTICE

ISOMET CORP, 5263 Port Royal Rd, Springfield, VA 22151, USA.

Tel: (703) 321 8301 Fax: (703) 321 8546

E-mail: ISOMET@ISOMET.COM Web Page: WWW.ISOMET.COM

Quality Assured.

In-house: Crystal Growth,
Optical Polishing,
A/R coating, Vacuum Bonding



1202-4

Acousto-Optic Modulator



1106

OUTLINE DRAWING

Dim'n: mm
1 inch = 25.4mm

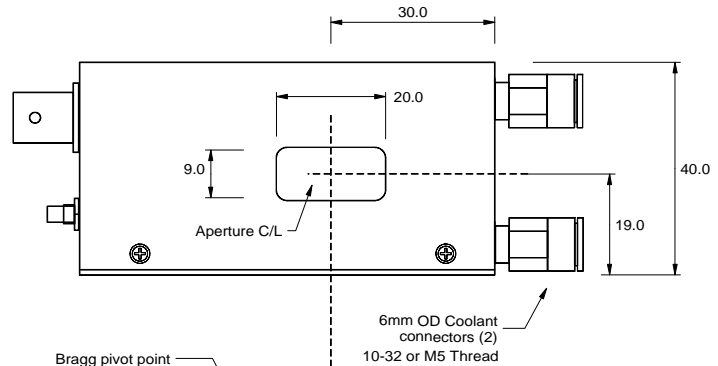
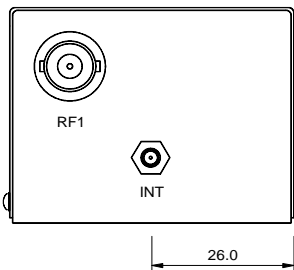

THIS DEVICE REQUIRES WATER COOLING TO PREVENT THERMAL RUNAWAY THE INTEGRAL NC THERMAL INTERLOCK SWITCH OPENS AT 32 degC

THE WATER COOLED CASE PARTS ARE ALUMINIUM IT IS RECOMMENDED THAT A CORROSION INHIBITOR SUCH AS 'COPAL' BY FERNOX IS ADDED TO THE COOLING SYSTEM

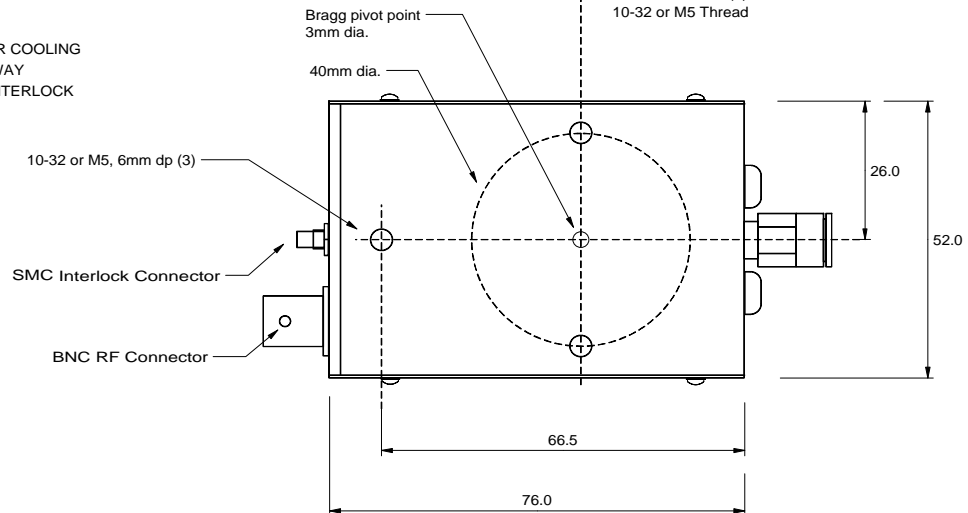

Recommended Driver

Modulator Driver/Amplifier

RFA141

ALL SPECIFICATIONS SUBJECT TO CHANGE WITHOUT NOTICE

ISOMET CORP, 5263 Port Royal Rd, Springfield, VA 22151, USA.

Tel: (703) 321 8301 Fax: (703) 321 8546

E-mail: ISOMET@ISOMET.COM Web Page: WWW.ISOMET.COM

Quality Assured.
In-house: Crystal Growth,
Optical Polishing,
A/R coating, Vacuum Bonding